

---

## MANUAL FOR GEARED TRACK TENSIONING TOOL

---



Please read through and understand this manual before using the tensioning tool.  
Original manual

March 2024 EN\_1

---

## Explanation of symbols

---

**Warning!**

The track tensioning tool can be dangerous. Careless or incorrect use can result in serious injury. Please read through the manual carefully and understand its contents before using the tensioning tool.

**Risk of crushing**

There is a risk of crushing when using the track tensioning tool.

**Manual**

Read through the manual carefully and understand its contents before using the tensioning tool.

**Safety boots**

Always wear safety boots with steel toecaps and anti-slip soles.

**Hard hat**

Always wear an approved hard hat.

**Protective goggles**

Always wear protective goggles or a visor when cleaning.

**Protective gloves**

Always wear protective gloves.

**Hi-Vis vest**

Always wear a high visibility vest around the base machine.

---

## Declaration of conformity

---

In accordance with the EC's Machinery Directive 98/37/EC  
Certificate in accordance with 98/37/EC, Appendix 2A.

Manufacturer Olofsfors AB  
Olofsfors 11  
SE-914 91 Nordmaling, Sweden

Machine no.: 035-489400 Geared track tension tool including  
035-489300 Gear housing

Serial no.: 128300->

The manufacturer hereby declares that the equipment supplied is in compliance with the following directive and national standards.

98/37/EC Machinery Directive, MD

The equipment is subject to the EC Directive for CE Marking, which is why an inspection of the machine has been performed. In this document, we (Olofsfors AB) explain the method used to comply with applicable EC directives with associated harmonised standards, as well as Swedish legislation and ordinances.  
Standard EN ISO 12100-1,-2 has been used as the basis for this declaration.

Reservation:  
The equipment may only be used for its intended purpose.

Olofsfors, date 2008-12-03

Niklas Swanemar, MD



## Technical description

With the aid of a cordless screwdriver, this tool is designed to mechanically tension Olofsfors bogie tracks on base machines fitted with rubber tires. (e.g. harvesters, forwarders).

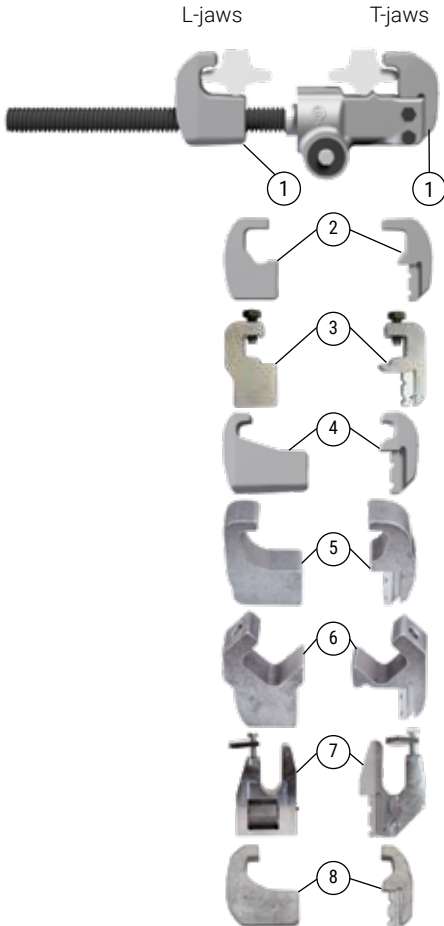

### Jaw kits

1.	ECO	035-489410
2.	OF	035-489420
3.	KovaX+	035-489530
4.	Baltic	035-489430
5.	U	035-489440
6.	EVO	035-489470
7.	EX	035-489480
8.	CoverX, CoverB	035-489520

## Safety instructions



Risk area.

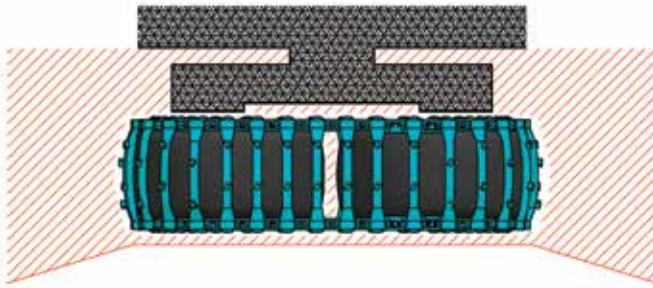

Be aware of the risk area around the base machine.



There is risk of crushing around track tensioning tool and tracks. Don't place arm/hand inside the track during tensioning, use the extension. The tensioner is designed for Olofsfors tracks. Usage on other track brands is prohibited since this could cause incorrect loads that can damage the tensioner.

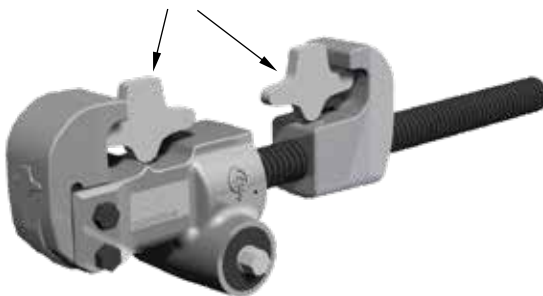

**Incorrect assembly.** Read and understand the assembly instructions for tracks before using the tensioning tool.



**Warning:** The track can jam when pulled over the wheels.

## Safety instructions

Be aware of the base machine's mobility.

Use  Hi-Vis vest,  hard hat and  safety boots.



Ensure that you have eye contact with the base machine's operator before approaching.



Use  protective goggles and  protective gloves during cleaning.



Do not overload the tensioner. Max. input torque is 30Nm. Overloading can damage the tensioner. **Do not use impact wrench!**



To cut steel strapping during unpacking, place the track upright on a flat surface to avoid the risk of the track rolling away.

Use  protective gloves,  
 protective goggles and  safety boots.



This tensioning tool must not be used for anything other than tensioning Olofsfors bogie tracks, in accordance with assembly/dismantling instructions (see page 23).

## Assembly of geared track tensioning tool



- Remove the M10 screws (18) and insert the chosen T-jaw down into the groove.
- Replace and tighten the M10 screws (18).
- Screw the chosen L-jaw onto the spindle (15).
- Fit the extension to a screwdriver or drill that can be prevented from overloading the track tensioning tool. **Note** that the maximum input torque is 30Nm. Olofsfors recommends a screwdriver with torque control.

### In addition to the track tensioning kit, the following equipment is also required:

The recommended personal safety equipment

M10 tool (A/F=16 mm)

M12 tool (A/F=19 mm)

M14 tool (A/F=22 mm)

M20 tool (A/F=30 mm)

Screwdriver with torque control

Strap

Hammer

Wire cutter

Pry bar

Crane



## Assembly Instruction Bogie-Tracks



The track pair is supplied as 4 rolls on 2 pallets. The rolls on the same pallet is to be connected with each other. Never mix tracks from different pallets!

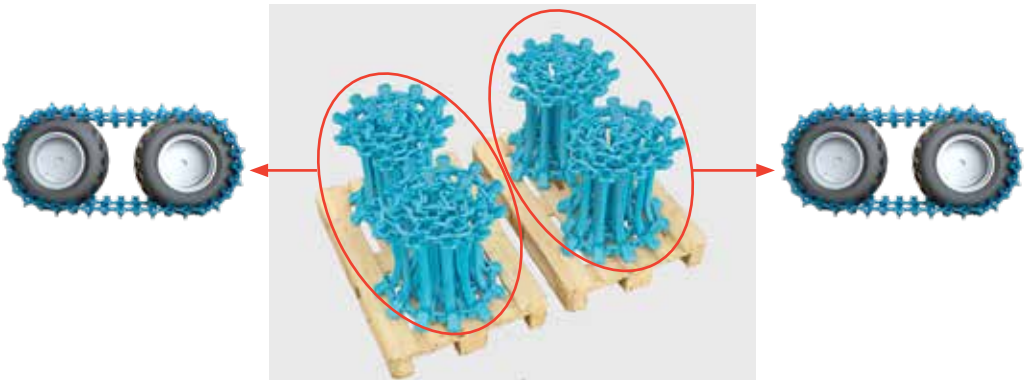

*Ensure that the information on the track marking tags corresponds with the attached documents.*

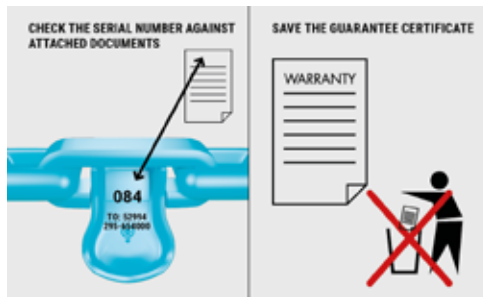

*Save the warranty certificate!*

Place the track pallets on even ground and cut the plastic straps. Exercise caution! Overturn the roll using the machine crane.

Lay out the tracks straight, with the side supports facing down. Assemble the 2 track halves with the medium length track locks.



---

## Assembly instructions

---



1. Secure a strap around the outermost cross member, pass the strap over the tire and drive over the strap with the bogie to pull up the tracks.



2. Stop the machine when the track is positioned according to the picture.



3. Mount the two clamps from the outside into the link hooks.



4. Drive slowly forward until the clamps are between the bogie wheels.



5. Mount the tensioner from underneath and make sure it's in the middle of the cross bar. **ATTENTION!** Wet new tires with water to ease installation. Use a pry bar if the track cross bars gets stuck in the tire pattern.



6. Use the screwdriver with the extension and tighten the track slightly.



7. Dismantle the clamps.

---

## Assembly instructions

---



- 8.** Continue tightening the track until a suitable track lock can be fitted. The lock must be mounted from the inside.



- 9.** Install the track lock plate.

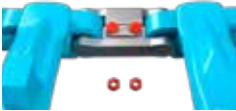

- 10.** Mount the screws from above. This protects the nut and protruding thread from damage when driving.



- 11.** Run the screwdriver backwards to release the tensioner from the cross members. Remove the tensioner. Correct track tension is achieved when the sag between the tires is no more than 50mm (2").

## Dismantling bogie tracks



Unscrew the track lock plates and knock out the track lock clamps with a knock-out bar or similar tool. Ensure that everyone is clear from the risk area and drive the machine away from the bogie tracks.

## Maintenance

---



### **Spindle – straightness**

Check the straightness of the spindle. Replace the spindle if it is bent.

### **Cleaning the spindle**

If the spindle becomes dirty, it must be brushed clean and regreased. Use gloves and protective goggles when the spindle is brushed clean.

### **Check that there are no cracks in the gear or jaws**

If there are cracks in the gear or jaws, these must be discarded.

### **Check that the clamps are at a right angle**

If the clamps are bent, they must be discarded.

### **Check play on the gear**

Maximum permitted input shaft play is 45°.

If the play is greater than this, the gear must be discarded.

If the claw has a clamping screw, check to ensure it turns easily. If the screw is difficult to turn it is damaged and should be replaced before the threads in the claw are destroyed.

## Technical data

### Technical data

Weight, tensioning tool without jaws	10 kg / 22 lbs
Weight, tensioning tool with jaws	max 15 kg / 33 lbs
Max. permitted input torque on gear	30Nm / 22 FT LB
Max. output force	3,000 kg / 6600 lbs
Min. operating temp.	-30 °C Fahrenheit

## Spare parts list

- |                          |            |
|--------------------------|------------|
| 1. Extension             | 035-489398 |
| 2. Clamps                | 035-470130 |
| 3. Grease                | 035-489372 |
| 4. Brush                 | 035-489375 |
| 5. Case                  | 035-489360 |
| 6. Spindle               | 035-489290 |
| 7. Input shaft           | 035-489393 |
| 8. Shear pin kit, 10 pcs | 035-489305 |
| 9. Screw M6S             |            |
| M10x60 10.9              | 950-500450 |
| 10. Clamping screw M20   |            |
| OF, EVO, KovaX/KovaX+    | 035-489382 |

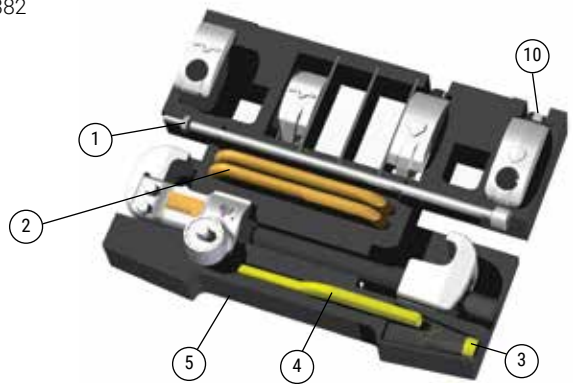
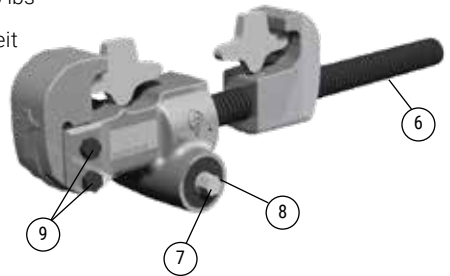



---

## Contacts

---

### Olofsfors AB

**Address:** Olofsfors 11  
SE-914 91 Nordmaling  
Sweden

**Phone:** +46 930-311 40

**E-mail:** [order@olofsfors.se](mailto:order@olofsfors.se)

**Opening hours:**

Mon-Thu 07:30-16:00 Local time

Friday 07:30-15:00 Local time

Lunch hour 12:00-13:00 Local time

### Olofsfors Inc

**Address:** 121 Roy Blvd., Unit 4  
Brantford, Ontario, Canada  
N3R 7K1

**Phone:** +1 519 754 2190

**Fax:** +1 519 757 1100

**E-mail:** [info@olofsfors.com](mailto:info@olofsfors.com)

**Opening hours:**

Mon-Fri 8am-5pm EST

### Olofsfors GmbH

**Address:** Auf der Röte 1  
DE-75397 Simmozheim  
Germany

**Phone:** +49 (0) 7033 32043 10

**E-mail:** [order.gmbh@olofsfors.de](mailto:order.gmbh@olofsfors.de)

**Opening hours:**

Mon-Fri 8am-5pm EST

### Metsätyö OY Rovaniemi

**Address:** Alakorkalontie 42  
FI-96300 Rovaniemi  
Finland

**Phone:** +358 16 321 0100

**E-mail:** [info@metsatyo.fi](mailto:info@metsatyo.fi)

**Opening hours:**

Mon-Thu 08:00-16:00 Local time

### Metsätyö OY Jyväskylä

**Address:** Kiilatie 5  
FI-40320 Jyväskylä  
Finland

**Phone:** +358 14 338 8700

**E-mail:** [info@metsatyo.fi](mailto:info@metsatyo.fi)

**Opening hours:**

Mon-Thu 08:00-17:00 Local time

### Metsätyö OY Hämeenlinna

**Address:** Kiltintie 13  
FI-13130 Hämeenlinna  
Finland

**Phone:** +358 3 644 0400

**E-mail:** [info@metsatyo.fi](mailto:info@metsatyo.fi)

**Opening hours:**

Mon-Thu 08:00-17:00 Local time

### Olofsfors Ltda.

**Address:** Rua Mateus Leme, no. 1970  
Piso Térreo – Centro Cívico  
CEP 80.530-100 Curitiba – PR  
Brasil

**Phone:** +55 11 97373 0201

**E-mail:** [order@olofsfors.com/br](mailto:order@olofsfors.com/br)

**Opening hours:**

Mon-Fri 8am-5pm EST

### Olofsfors LLC

**Address:** Kazakhstan,  
Almaty, Shumny pereulok, 5  
Russia

**Phone:** +7 777 053 58 87

**E-mail:** [info.ru@olofsfors.com](mailto:info.ru@olofsfors.com)

**Opening hours:**

Mon-Fri 7:30am-4pm EST